

MODEL DWARSPROFIEL HEIRWEG:

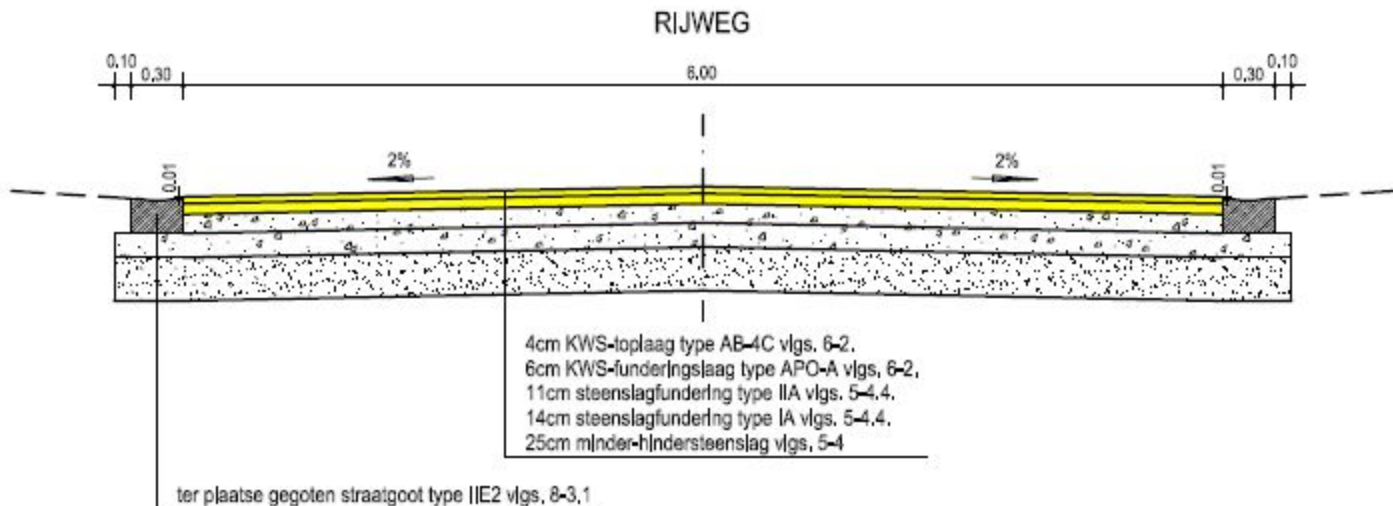

MODEL DWARSPROFIEL LEEBEEKSTRAAT:

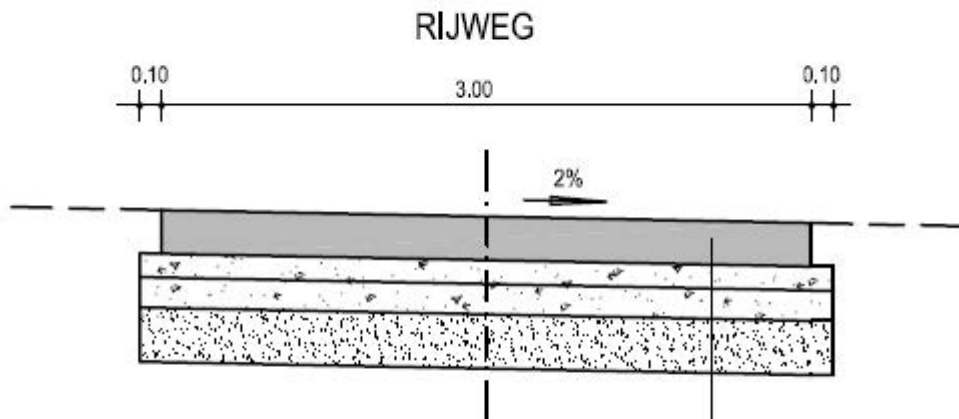

20cm uitgewassen cementbetonverharding met porfier volgens 6-1
11cm steenslagfundering type IIA vlg. 5-4,4,
14cm steenslagfundering type IA vlg. 5-4,4,
25cm minder-hindersteenslag vlg. 5-4

MODEL DWARSPROFIEL PROFIEL 27-47:

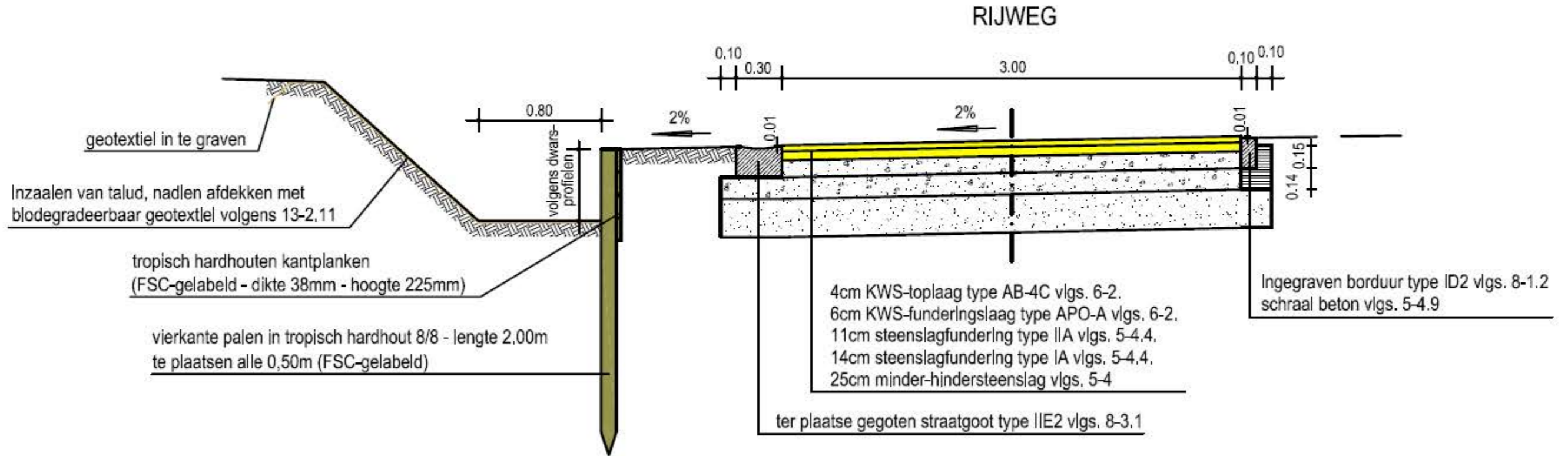

MODEL DWARSPROFIEL PROFIEL 21-26:

RIJWEG

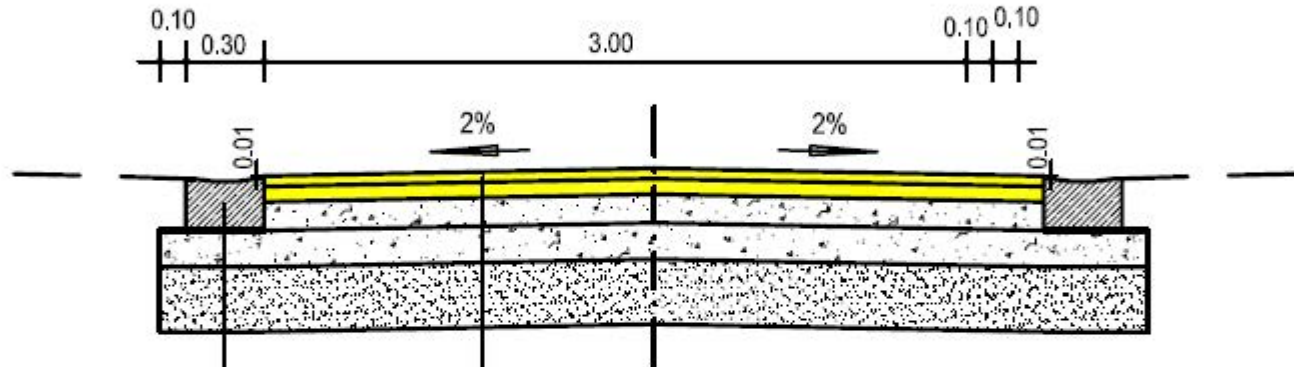

4cm KWS-toplaag type AB-4C vlg. 6-2,
6cm KWS-funderingslaag type APO-A vlg. 6-2,
11cm steenslagfundering type IIA vlg. 5-4.4,
14cm steenslagfundering type IA vlg. 5-4.4,
25cm minder-hindersteenslag vlg. 5-4

ter plaatse gegoten straatgoot type IIE2 vlg. 8-3.1

MODEL DWARSPROFIEL PROFIEL 9-21:

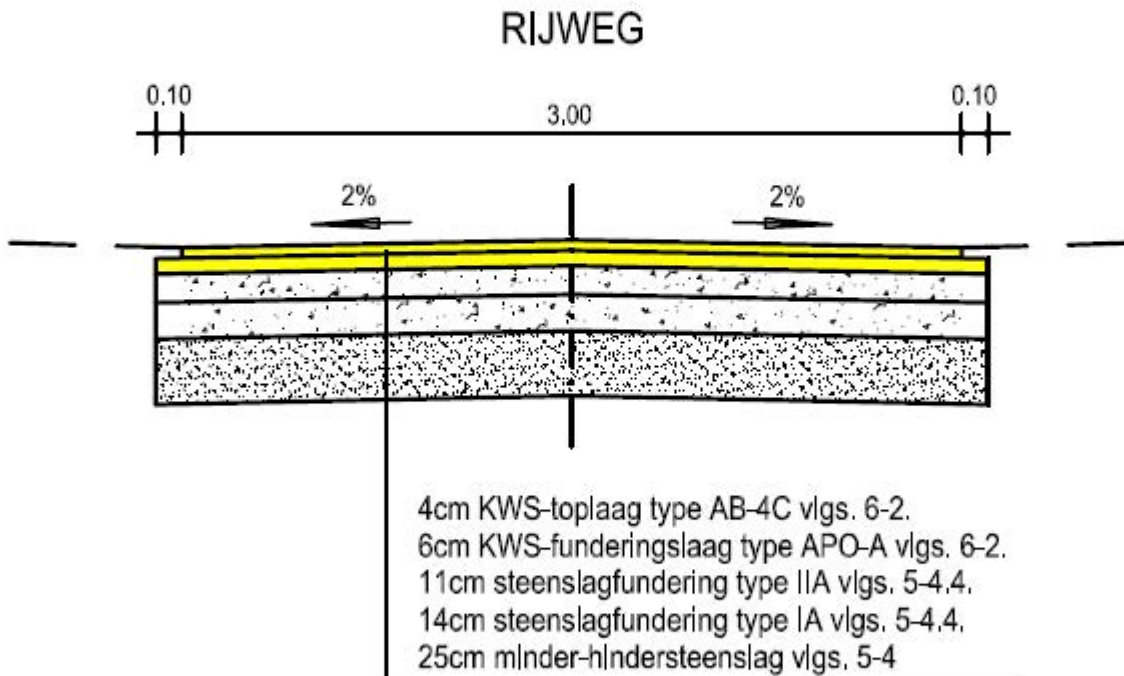

MODEL DWARSPROFIEL PROFIEL 48-51:

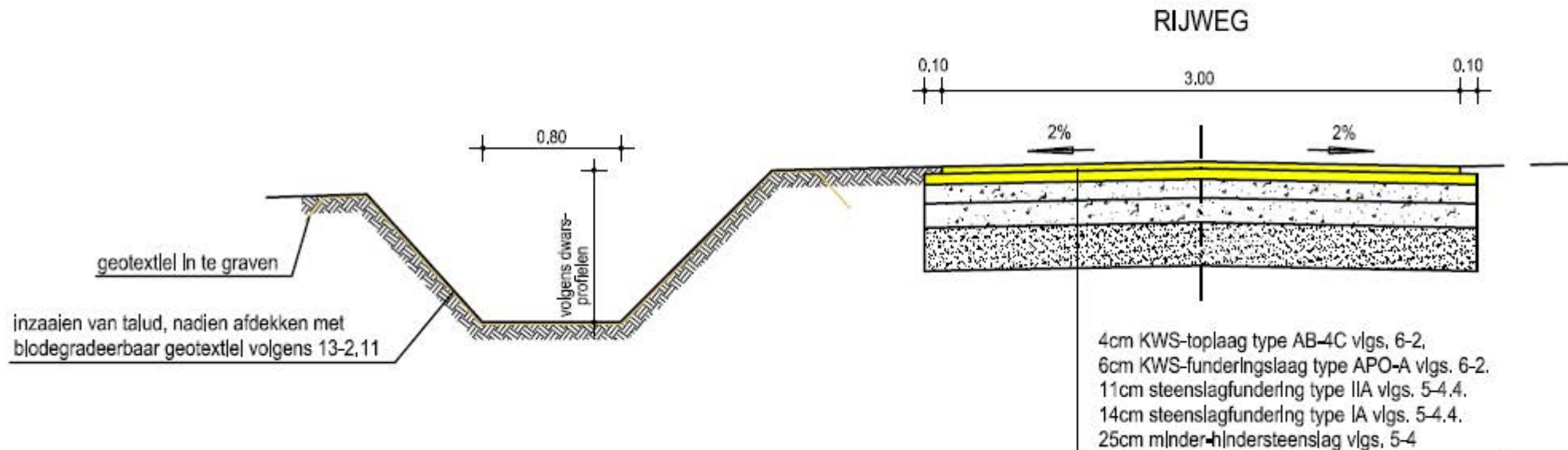

MODEL DWARSPROFIEL PROFIEL 52-70:

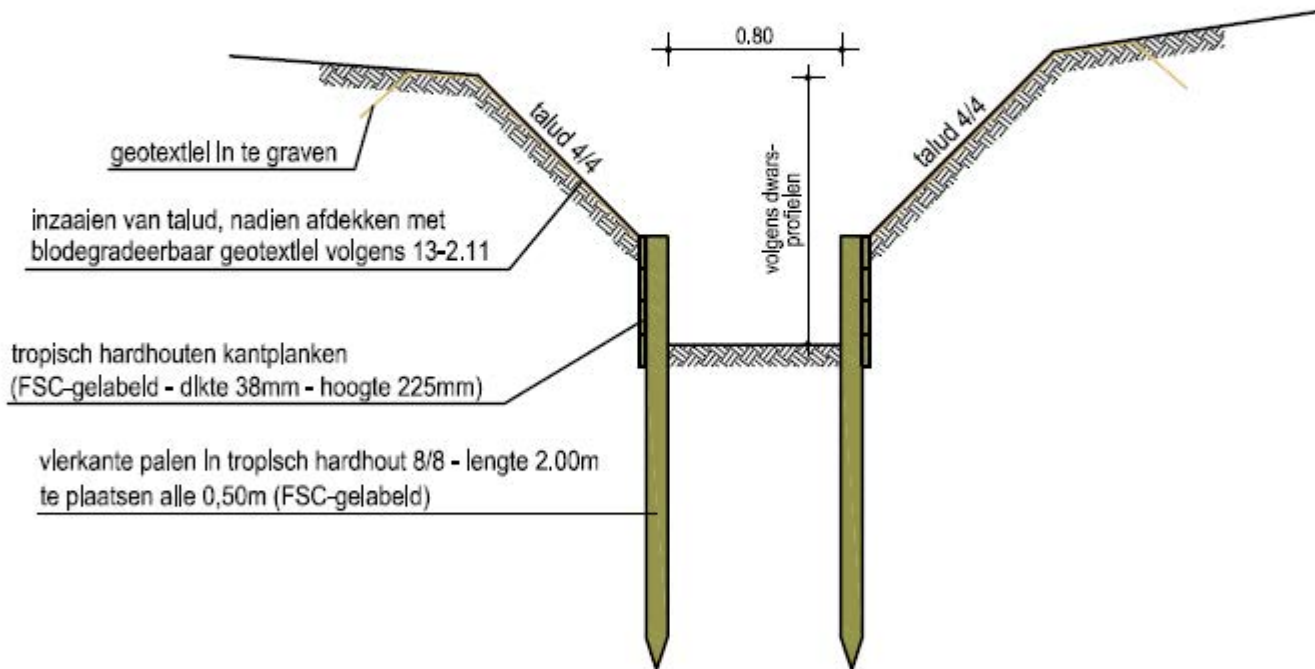

MODEL DWARSPROFIEL PROFIEL 70-74:

